

# SPECIFICATION SHEET



**PRODUCT CODE:** PEX-226A-C/P

**DESCRIPTION:**

1/2" x 1/2" luxury angle valve

**FINISH:** Chrome

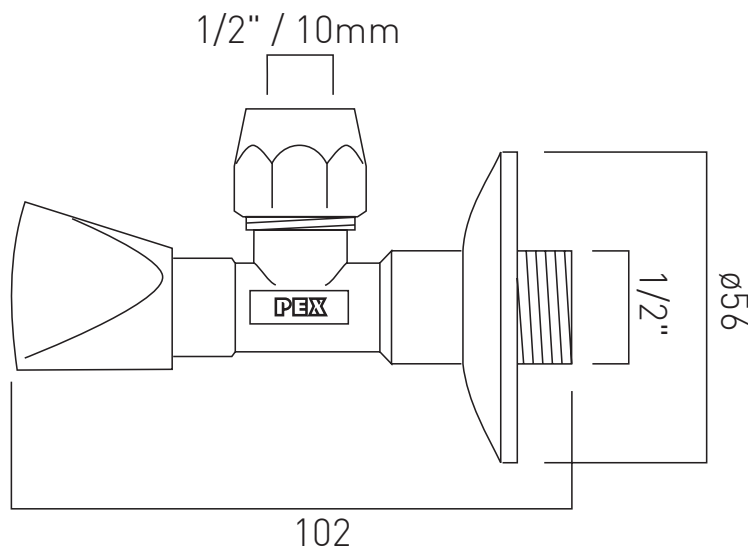

standard packing details	
item weight (kg)	0.232
inner box contains	1
box weight (kg)	0.255
outer carton contains	100
carton weight (kg)	26
full pallet contains	2200
pallet weight (kg)	587

tel: +44 (0)1934 745160  
email: [export@vado.com](mailto:export@vado.com)  
[www.vado.com](http://www.vado.com)

