

SPECIFICATION SHEET



PRODUCT CODE: PEX-233A-C/P

DESCRIPTION:

quarter turn angle valve 1/2" x 1/2"
(supplied with both hot and cold indices)

FINISH: Chrome

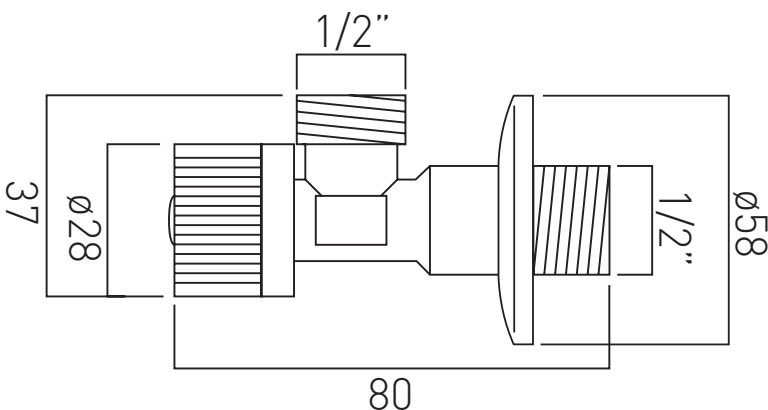

standard packing details	
item weight (kg)	0.93
inner box contains box weight (kg)	1 0.113
outer carton contains carton weight (kg)	100 11.5
full pallet contains pallet weight (kg)	2800 337

tel: +44 (0)1934 745160
email: export@vado.com
www.vado.com

